

Homework #8

Problem 5.10-7 A cantilever beam AB of length $L = 6.5$ ft supports a uniform load of intensity q that includes the weight of the beam (see figure). The beam is a steel $W 10 \times 12$ wide-flange shape (see Table E-1, Appendix E).

Calculate the maximum permissible load q based upon (a) an allowable bending stress $\sigma_{\text{allow}} = 16$ ksi, and (b) an allowable shear stress $\tau_{\text{allow}} = 8.5$ ksi. (*Note:* Obtain the moment of inertia and section modulus of the beam from Table E-1.)

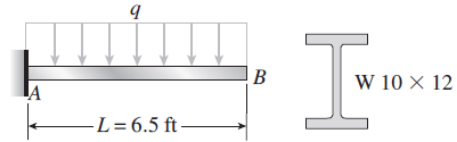

Problem 5.10-8 A bridge girder AB on a simple span of length $L = 14$ m supports a uniform load of intensity q that includes the weight of the girder (see figure). The girder is constructed of three plates welded to form the cross section shown.

Determine the maximum permissible load q based upon (a) an allowable bending stress $\sigma_{\text{allow}} = 110$ MPa, and (b) an allowable shear stress $\tau_{\text{allow}} = 50$ MPa.

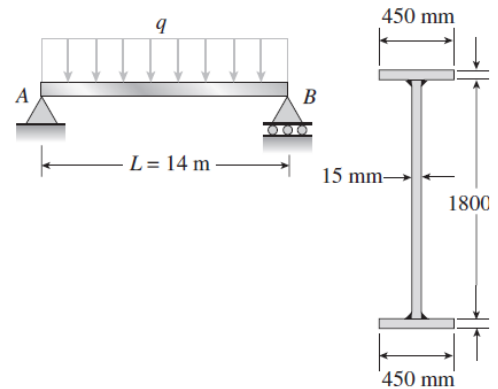

Problem 5.10-12 The T-beam shown in the figure has cross-sectional dimensions as follows: $b = 220$ mm, $t = 15$ mm, $h = 300$ mm, and $h_1 = 275$ mm. The beam is subjected to a shear force $V = 60$ kN.

Determine the maximum shear stress τ_{max} in the web of the beam.

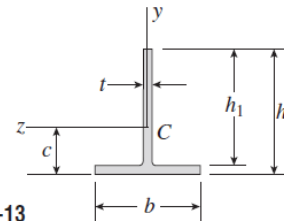

Probs. 5.10-12 and 5.10-13

Problem 5.11-5 A box beam constructed of four wood boards of size 6 in. \times 1 in. (actual dimensions) is shown in the figure. The boards are joined by screws for which the allowable load in shear is $F = 250$ lb per screw.

Calculate the maximum permissible longitudinal spacing s_{max} of the screws if the shear force V is 1200 lb.

